

## ***Owner's manual***

Southeastern Industrial Resources, Inc.  
P.O. Box 266  
5700 Columbus City Road  
Grant, AL 35747

256-728-3070  
256-728-3071 (fax)

**Order online at**  
[www.rip-saw.net](http://www.rip-saw.net)

Refer to Ripsaw owners' information online at  
[www.rip-saw.net/owners.html](http://www.rip-saw.net/owners.html) for instructions and parts information

# *Table of Contents*

Safety instructions .....	1
Assembly	
Chainsaw assembly and preparation .....	2
Compatible chainsaws and sprockets .....	2
RIPSAW assembly .....	3
Dimension plate assembly .....	4
Guide beam assembly.....	5
End clamp assembly .....	6
Blades	
Changing blades .....	11
Tracking blades	
Drive wheel .....	12
Idler wheel .....	12
Sharpening blades .....	13
Carbide guide adjustment/replacement .....	11
Log capacity .....	14
Sawing wood .....	15
Parts diagrams	
Front covers .....	7
Ripsaw .....	10
End clamps .....	6
Parts list .....	8-9
Warranty / Guarantee .....	16

## *Safety instructions*

Proper operation of The **RIPSAW** is essential to avoid serious personal injury to the operator and bystanders. Keep hands, feet, face, and clothing away from all moving parts of the saw at **ALL TIMES**.

Read through the entire manual thoroughly. If you are uncertain of any procedures in this manual, please consult S.I.R. for assistance. (256) 728-3070.

1. Always wear eye and ear protection while operating the **RIPSAW** or chainsaw.
2. If you plan to rest the log on trestles, be sure that they are steady and at a comfortable height for you to work with.
3. Before starting the saw, make sure that the log is secure and that it will not move while you are pushing the saw through it.
4. The use of the **RIPSAW** is a one-person operation. If you should require assistance in moving logs or cut lumber, ensure that the person is wearing protective equipment and keep at a safe distance from the sawmill while it is in operation.
5. For re-fueling gasoline powered sawmills, extinguish all smoking materials, stop the engine and allow it to cool. prepare the gas/oil mixture as instructed in your chainsaw owner's manual.
6. Keep the blade guard closed until just before starting a cut.
7. Keep all spectators at least 20 feet away from the milling operation.

# Stihl Chainsaw assembly/preparation

(When providing your own chainsaw)

1. Clean the mounting surface on the powerhead and remove the following parts.  
(Retain these parts for future use.)

**NOTE: Be sure that the chain brake is disengaged.**

- a. 2 bar nuts
  - b. chain/sprocket cover
  - c. bumper spike, bolts and nuts which fasten it
  - d. snap ring from crank shaft
  - e. large washer from crank shaft
2. A 7 tooth spur gear sprocket is required to run the sawmill with some Stihl models.
  3. Replace the sprocket if necessary.  
(See chart below)
  4. Place small washer onto crankshaft.
  5. Secure washer with the snap ring you previously removed.
  6. Apply liquid gasket material to shaded area in diagram below.
  7. Adjust bar oiler flow to a minimum, by inserting a small screwdriver into slot located on the bottom of the powerhead and turning it counterclockwise.
  8. Attach powerhead to the **RIPSAW** using the instructions on page 3.



**MAKE SURE BAR OILER CONTAINS AN AMPLE SUPPLY OF OIL.  
FAILURE TO DO SO WILL RESULT IN RIPSAW GEAR FAILURE.**

Compatible chainsaws for adaptation to the  
Ripsaw portable sawmill

**Stihl models:** 028, 029, 034, 036, 036PRO, 038, 039, 044, 046, 064, and 066, MS290, MS360, MS380, MS390, MS440, MS460, MS660, E20 and MSE220 electrics  
**Jonsereds models:** 2065, 2165, 2071  
**Husquvarna models:** 365, 371, 395

## Stihl sprocket part numbers

Stihl 026	1121 640 2003
Stihl 026 w/adj. oiler	1121 640 2004
Stihl 028, MS280	1118 640 2003
Stihl 029, MS290	1125 640 2004
Stihl 034	1125 640 2004
Stihl 036, MS360	1125 640 2004
Stihl 038, MS380	1119 640 2000
Stihl 039, MS390	1125 640 2004
Stihl 044/046,	
MS440, 460	1128 640 2000
Stihl 064/066, MS660	1122 640 2002

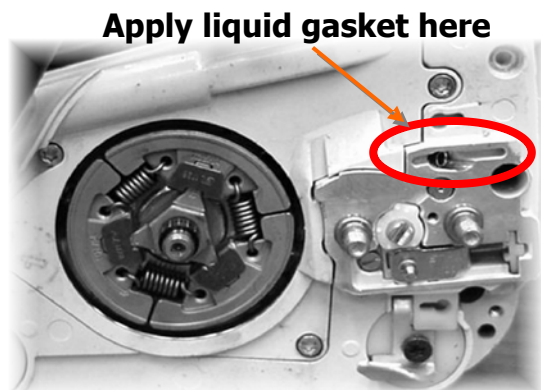

## *Assembly instructions*

*RIPSAW accessories are located inside guide beams*

1. Release blade tension by loosening tension bolt.
2. Loosen and remove cover knobs from front cover plates.
3. Remove Drive cover plate from sawmill. (plate with **RIPSAW** decal)
4. Remove bar nuts from chainsaw.
5. Position chainsaw studs through adapter block on **RIPSAW**.
6. Rotate sprocket to engage drive mechanism.
7. Re-install bar nuts into recesses in adapter and tighten them securely.
8. Re-install Drive cover plate. (Be sure that locating pins are through the holes in cover plates before installing and tightening cover knobs.)
9. Re-install cover knobs and tighten securely.
10. Tighten the tension bolt until the indicator reaches the white line.

Refer to chainsaw owner's manual for the proper oil/gasoline ratio.

**Maintain an ample supply of bar and chain oil in the reservoir to lubricate the drive mechanism of the RIPSAW.**

## Dimension plate assembly

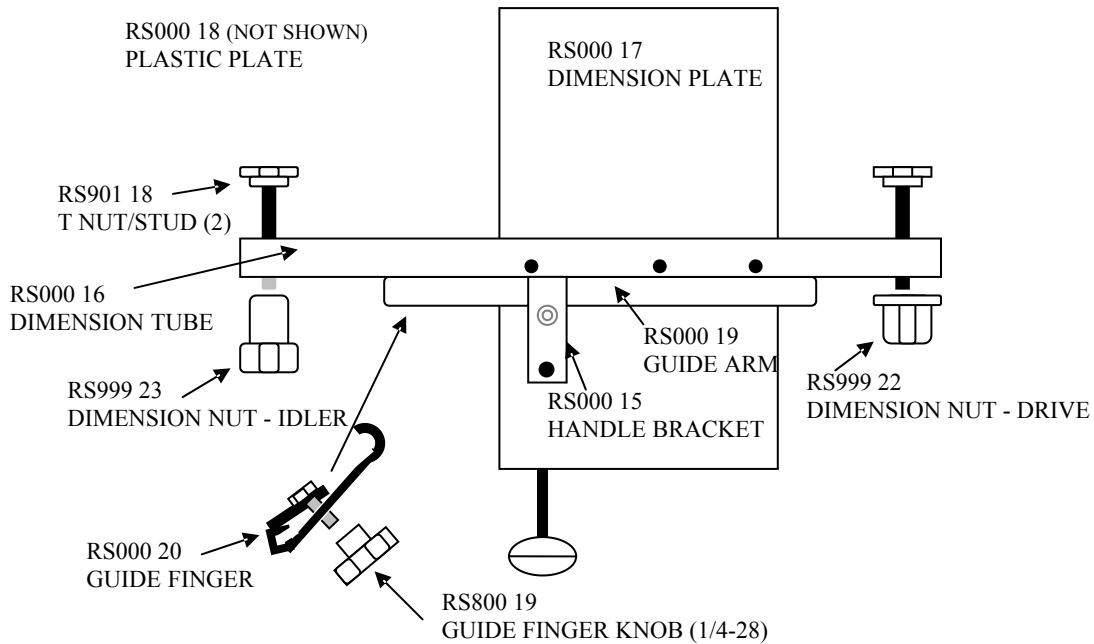

Figure 1. Dimension plate assembly

1. Remove dimension plate and parts from box.
2. Slide guide arm under handle bracket with square pin facing downward.
3. Install and tighten handle to secure guide arm.
4. Remove T nut studs from dimension plate.
5. Slide T nut studs through slots in rear drive and idler plates, with the threaded stud pointing towards you.
6. Attach dimension plate by putting studs through holes in dimension tube.
7. Install Dimension plate nuts.
8. Slide guide finger onto guide arm (*Figure 1*) and tighten knob.
9. Adjust guide arm and finger to accommodate the size of each log you cut.

## Guide beam assembly

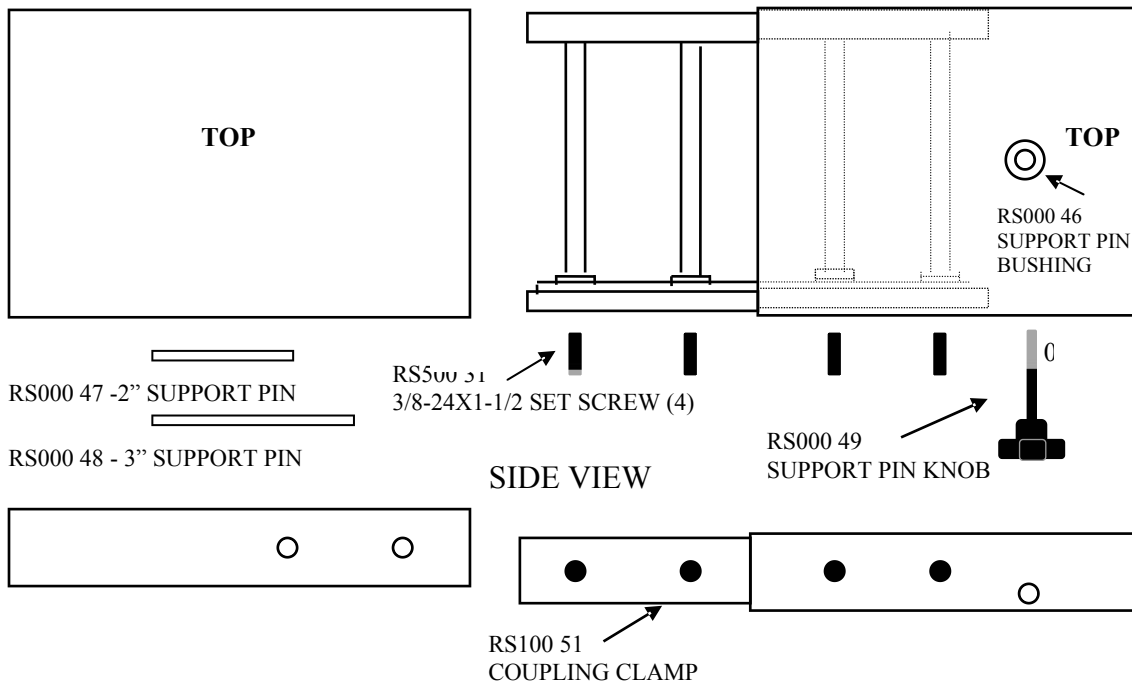

Figure 2. Guide beam assembly

1. Remove coupling clamp and other accessories from guide beam.
2. Install coupling clamp half way into guide beam with bushing.(Align set screws with holes.)
3. Lightly tighten the last setscrew to keep clamp from moving.
4. Place the end of the main guide beam onto clamp lining holes up with setscrews.
5. Secure guide beams by tightening all four setscrews.
6. Install proper support pin into bushing after placing beam on top of log.  
(The pin should not be above the top surface of the guide beam.)
7. Insert support pin knob and tighten it.

**Please note:**

Both the Guide Beams and End Clamps are made to be affixed on either the left or right side. It is imperative that you set up the machine with all of the knobs on the same side of the unit to avoid interference during the cutting process.

## *End clamp assembly*

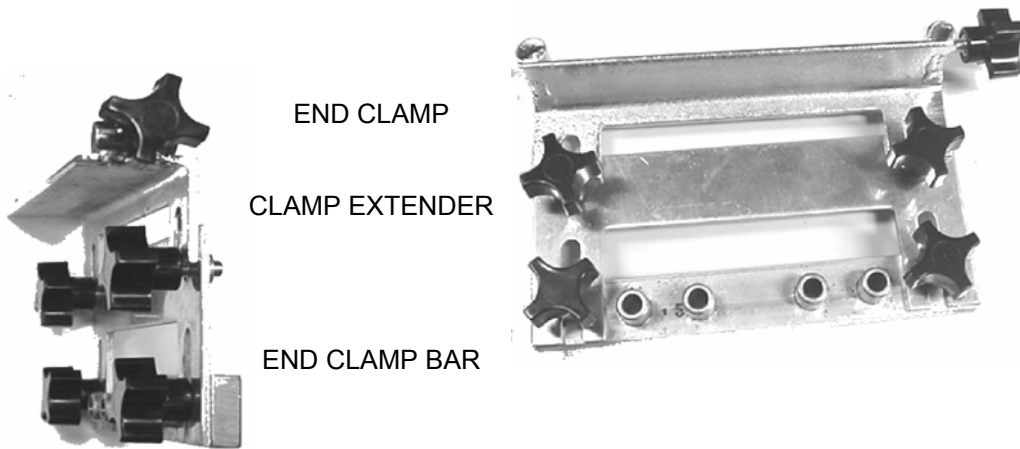
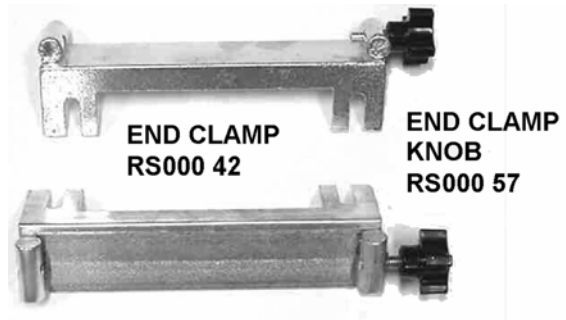

Install all knobs on the same side of log to avoid interference during the cutting process

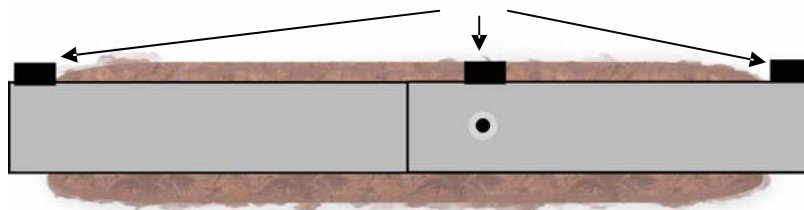

## *Front Drive Cover*

RS000 05 - Front Drive Cover with Blade Guard  
RS900 05 - Front Drive Cover without Blade Guard

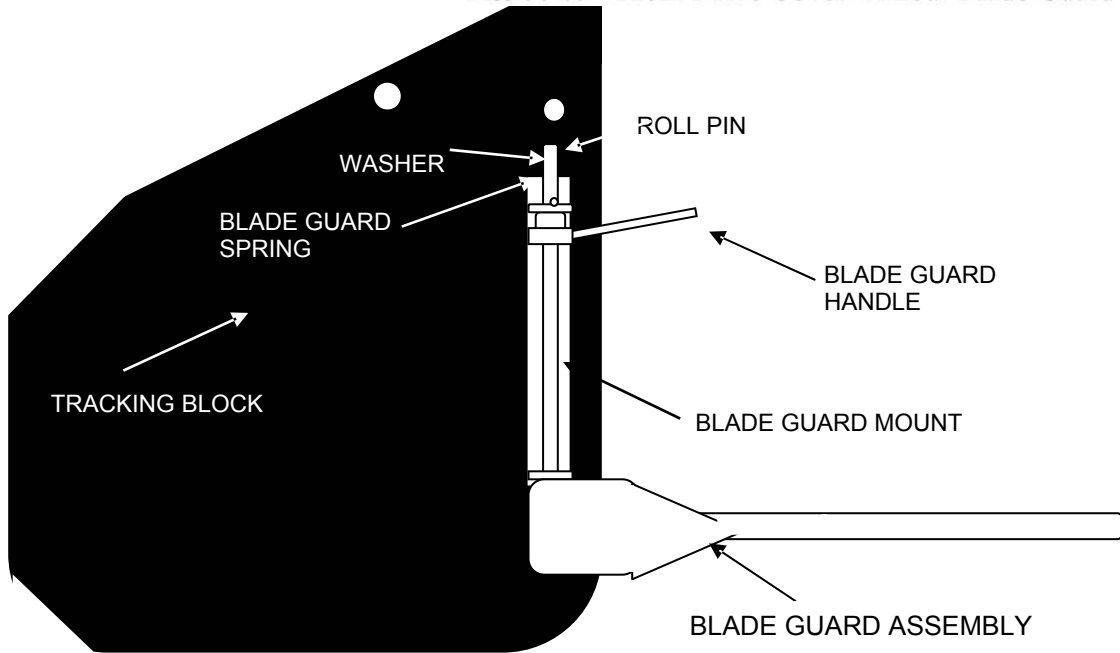

## *Front Idler Cover*

RS000 03  
FRONT TENSION ARM

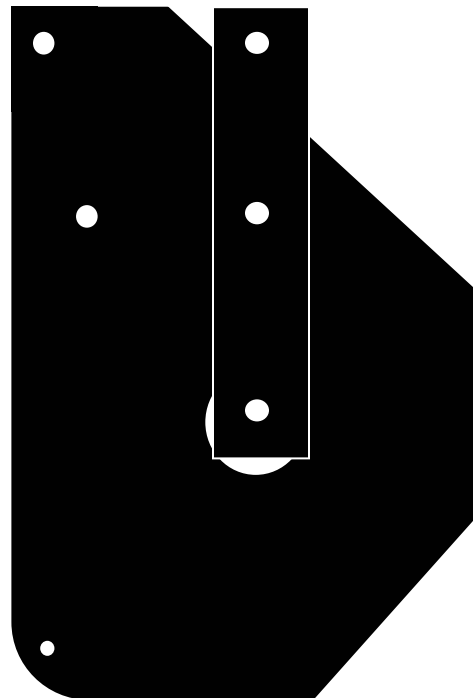

RS800 17  
COVER KNOB

## RIPSAW PARTS LIST

RS000 01	TOP TUBE	RS100 53	COUPLING CLAMP BASE
RS000 02	MAIN TUBE	RS100 54	COUPLING CLAMP NUT BAR
RS000 03	TENSION ARM-FRONT	RS100 55	END CLAMP BAR W/BUSHINGS
RS000 04	TENSION ARM.-REAR	RS100 56	WHEEL SCRAPER - IDLER
RS000 05	FRONT DRIVE COVER	RS100 63	END CLAMP KNOB
RS000 06	REAR DRIVE PLATE	RS500 11	5/16 -18X1-3/4 COUPLING NUT
RS000 07	FRONT IDLER COVER	RS500 12	1/16 -18X3 SOC CAP BOLT
RS000 08	REAR IDLER PLATE	RS500 14	1/4X3/4 ROLL PIN
RS000 09	REAR DRIVE COVER	RS500 15	10-32/3/8 FLAT HD SCREW
RS000 10	REAR IDLER COVER	RS500 16	10-32/3/8 BUT SOC CAP SCREW
RS000 11	LOCATING PIN	RS500 17	1/4-28X1 SET SCREW W PATCH
RS000 12	HEX PIN	RS500 18	1/4-20X3/4 FLAT HD SCREW
RS000 13	PIVOT PIN	RS500 19	5/32X3/8 ROLL PIN
RS000 14	AXLE	RS500 20	1/4-20X1/2 HEX BOLT
RS000 15	HANDLE BRACKET	RS500 21	1/4-20X1-1/4 HEX BOLT
RS000 16	DIM. PLATE TUBE	RS500 22	1/4-20 HEX NUT
RS000 17	DIMENSION PLATE	RS500 23	10-32X1/4 PAN HD SCREW
RS000 18	DIM. PLATE PLASTIC	RS500 24	10-32X5/8 PHIL PAN HD SCREW
RS000 19	GUIDE ARM	RS500 25	10-32X5/16 PAN HD SCREW
RS000 20	GUIDE FINGER	RS500 26	1/4-28X3/4 HEX BOLT
RS000 22	BLADE GUIDE BLOCK	RS500 27	10-32 KEP NUT
RS000 26	GUARD WIRE - DRIVE	RS500 28	1/4-20X5/8 HEX BOLT
RS000 27	GUARD WIRE - IDLER	RS500 29	1/4 ID FLAT WASHER
RS000 28	GUARD WIRE MOUNT	RS500 31	3/8-24X1-1/2 SET SCREW
RS000 29	TENSION ASSEMBLY	RS500 32	10-32X3/8 PHIL PAN HD SCREW
RS000 30	TENSION BOLT	RS500 33	1/4-20X1 SET SCREW
RS000 31	TENSION INDICATOR	RS500 34	3/8-16X2 SET SCREW
RS000 36	WHEEL SCRAPER - DRIVE	RS500 35	1/4-20X1-1/4 SET SCREW
RS000 38	BLADE GUARD PIVOT	RS500 36	1/4-28X1 SET SCREW
RS000 40	BLADE GUARD HANDLE	RS500 37	3/16X3/8 RIVET
RS000 42	END CLAMP	RS500 38	BLADE GUARD PIVOT
RS000 46	SUPPORT PIN BUSHING	RS500 39	1/4-20X7/8 SET SCREW
RS000 47	SUPPORT PIN - 2"	RS500 40	FENDER WASHER 5/16 ID
RS000 48	SUPPORT PIN - 3"	RS500 42	5/16-18X1-1/4 SLOT FLT HD SCREW
RS000 49	SUPPORT PIN KNOB/STUD	RS500 43	5/16-18 STOP NUT
RS000 51	TRACKING BLOCK	RS500 44	10-32X1-3/4 PAN HD BOLT
RS000 57	END CLAMP PIN	RS500 45	10-32X1-1/2 PAN HD BOLT
RS000 59	GUIDE BEAM W/BUSHING	RS500 46	10-32 HEX NUT
RS000 60	MAIN GUIDE BEAM	RS500 47	5/16 NUT
RS000 68	UPPER BLADE GUARD	RS500 70	BEARING - WHEEL/PINION
RS000 81	CLAMP EXTENDER	RS500 71	BEARING - BLADE GUIDE
RS001 01	DRIVE WHEEL	RS500 72	CARBIDE INSERT
RS001 02	IDLER WHEEL	RS700 01	TRIM HATCHET
RS100 28	AXLE BUSHING	RS700 02	LOG CLEANING BRUSH
RS100 37	BLADE GUARD ASSEMBLY	RS700 03	FRAMING SQUARE
RS100 51	COUPLING CLAMP	RS700 04	SAFETY GOGGLES
8 RS100 52	COUPLING CLAMP SPACER	RS700 05	BLADE SHARPENER

RS700 06	DIAMOND SHARPENING STONE	RS999 15	¼ -20 ALLEN BOLT (TRACKING)
RS700 80	BLADE	RSH00 11	DRIVE COUPLING
RS700 83	BLADE GUARD SPRING	RSH00 12	DRIVE DISK - ELECTRIC
RS700 84	ANTI-VIBRATION PAD	RSH00 13	ADAPTER BLOCK
RS800 11	DIMENSION PLATE KNOB	RSH00 15	PINION COVER
RS800 15	EXTENDER KNOB	RSH00 70	PINION SPACER
RS800 17	COVER KNOB	RSH50 44	RING GEAR
RS800 19	KNOB - GUIDE FINGER	RSH50 55	PINION GEAR
RS800 28	3/16 ALLEN WRENCH	RSH70 38	038 SPROCKET
RS800 37	1/8 ALLEN WRENCH	RSH70 39	064 SPROCKET
RS800 46	VIDEO	RSH70 47	036 SPROCKET
RS901 18	T NUT / STUD	RSH70 48	044 SPROCKET
RS999 22	DIMENSION PLATE NUT – DRIVE	RSH70 49	20" BAR - STIHL
RS999 10	IDLER TRACKING BRACKET	RSH70 50	CHAIN FOR 20" BAR
RS999 11	IDLER TRACKING NUT	RSH70 51	STIHL WASHER
RS999 12	¼ -20 X 2 STUD	RSH70 52	2.6 STIHL ENGINE OIL
RS999 13	TRACKING WASHER	RSH70 53	STIHL BAR NUT
RS999 14	¼ - 20 NUT	RSH70 54	STIHL SNAP RING
		RSH90 55	PINION ASSEMBLY
		ST800 99	STIHL-20" BAR & CHAIN

# RIPSAW DIAGRAM

REAR VIEW

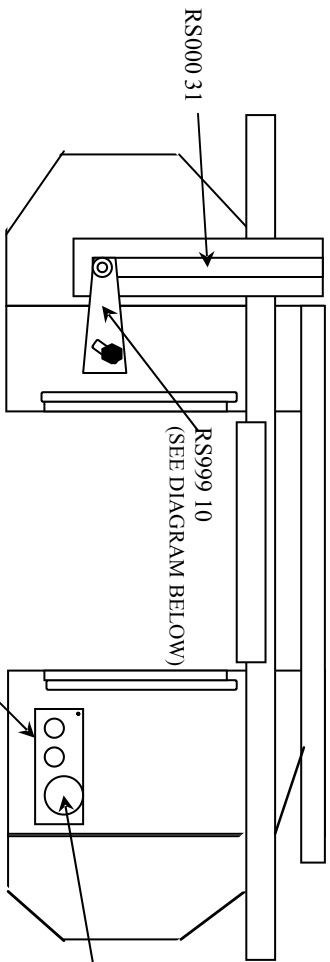

FRONT VIEW

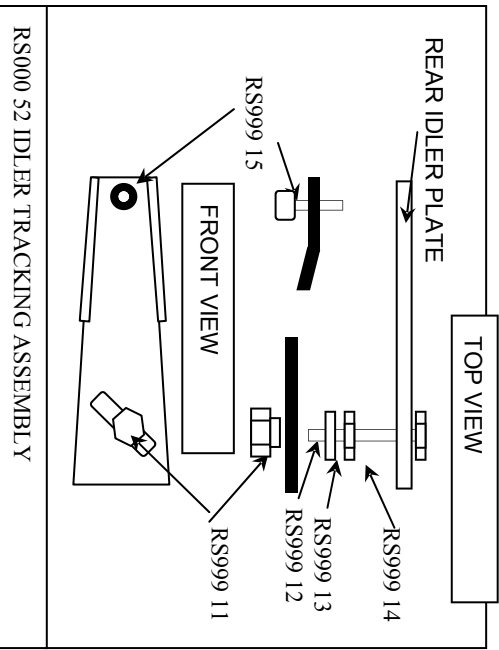
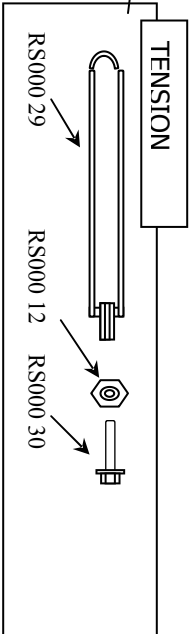
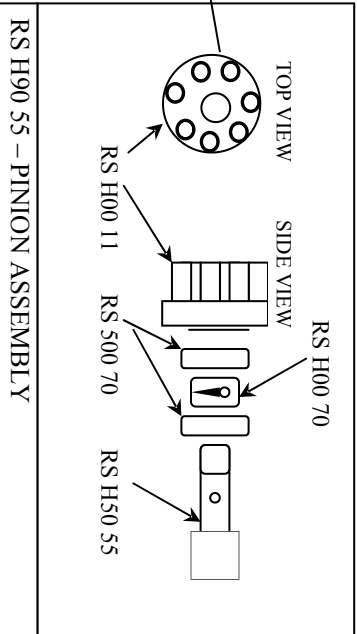
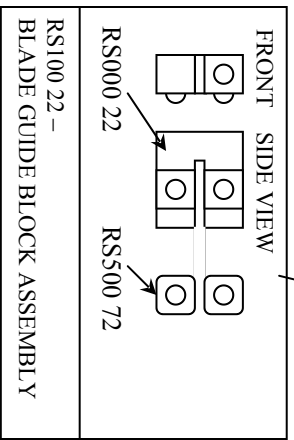
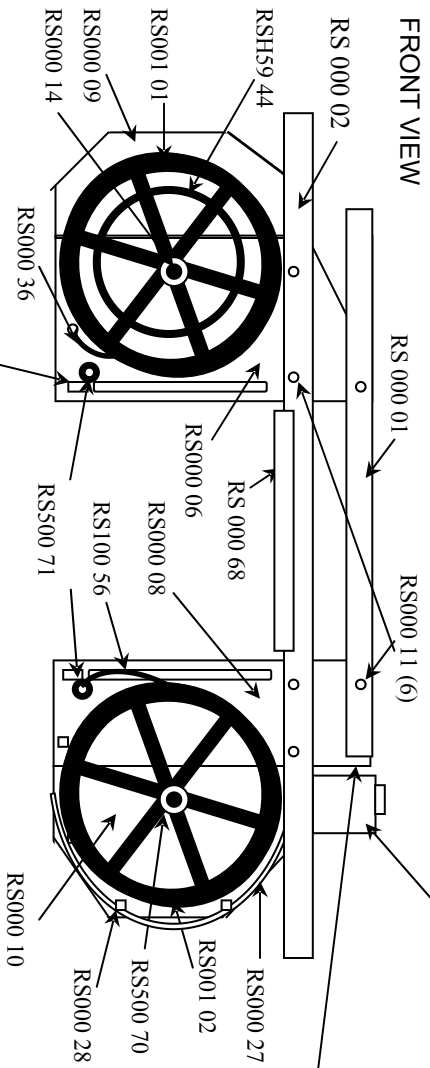

## *Changing blades*

Wear gloves and eye protection while handling blades.

1. Release blade tension. (Turn tension bolt counter-clockwise.)
2. Remove cover knobs.
3. Remove front tension arm, Drive cover and Idler cover.
4. Slide blade toward front of saw and out of guide blocks.
5. Slip blade over the edges of the bottom of the Drive and Idler wheels by tipping it up and outward.
6. Rotate blade up and out of safety guard.
7. To replace blade perform above procedures in reverse. Make sure that locating pins are through the holes in the front covers before installing and tightening cover knobs.
8. Tighten the tension bolt until the tension indicator reaches the white line on the rear tension arm.

## **Carbide guide replacement/adjustment**

Carbide guides may need to be adjusted occasionally. If your sawmill is making wavy cuts adjusting the carbide guides may solve the problem.

If using blades of thicknesses other than .025" you will need to adjust the carbide guides.

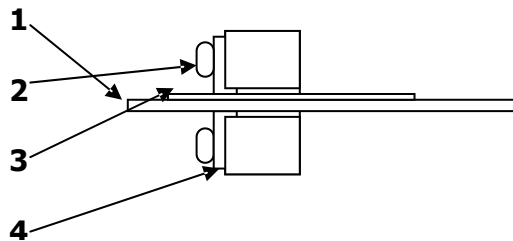

1. Install blade if necessary
2. Loosen screws
3. Place a piece of paper between blade and top carbide
4. Using vise grips or pliers, squeeze the carbides tother
5. Tighten screws while holding carbides in place

## Blade tracking

### Drive wheel...

The tracking set screw is located on the front drive cover at the wheel hub. Turning the set screw will move the wheel, which in turn will move the blade forward and backward. The smooth side of the blade should track approximately 1/32" from the rear rim of the Drive wheel.

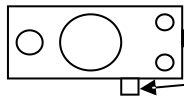

- a) Install a new blade if necessary.
- b) Loosen tracking lock screw.
- c) Adjust the Drive wheel tracking screw all the way in.
- d) Tighten the blade so that the indicator reaches the white line.
- e) Rotate the blade by hand to make sure that it will not come off the wheel when the saw is jogged (Jogging the saw consists of starting the motor and running the saw intermittently).
- f) Jog the saw while turning the tracking screw counterclockwise, until the blade leaves the back flange of the Drive wheel.
- g) Continue jogging the saw while adjusting the Idler wheel tracking bolt.
- h) Lock the Idler tracking bolt by tightening the 1/4-20 nut.

### Idler wheel...

The tracking adjustment for the idler wheel is located on the rear side of the sawmill.

1. Loosen locking nut, using a 7/16" open-end wrench.
2. Make tracking adjustment using a 3/4" wrench by turning tracking nut clockwise to move blade backwards (towards you) and turning nut counter-clockwise to move blade forward. (Away from you) You will need to follow the tracking nut with the lock nut to achieve the proper results.
3. Tighten locking nut.

The smooth side of the blade should track evenly with the rear edge of the Idler wheel.

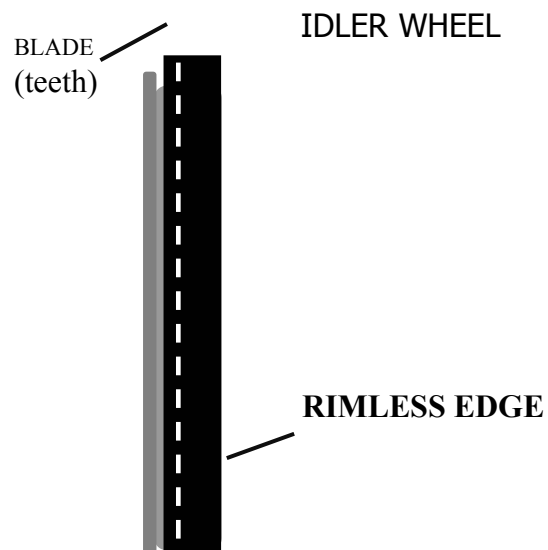
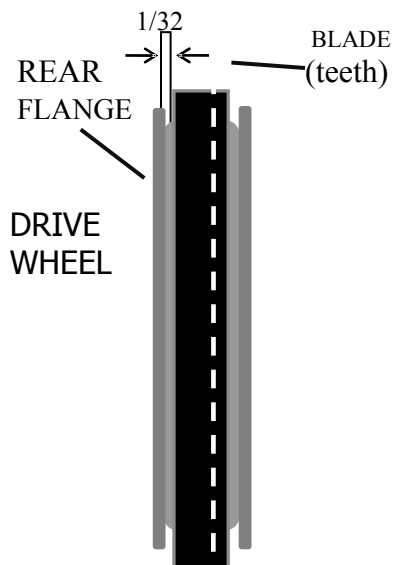
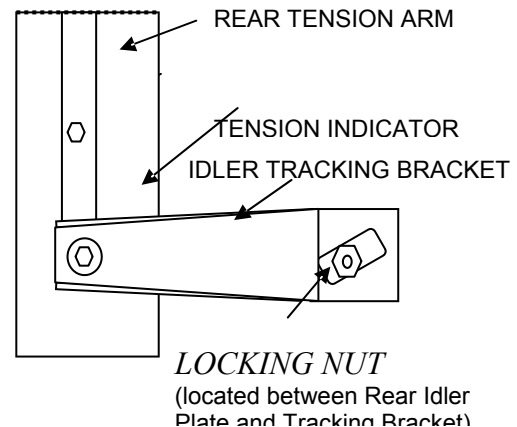

## Sharpening blades

**W**EAR SAFETY GOGGLES, FACE PROTECTION AND GLOVES WHILE SHARPENING BLADES

- 1) You will first need to remove the steel guide from the Oregon sharpener for sharpening Ripsaw saw blades.
- 2) It is recommended that you sharpen the blade while it is on the **RIPSAW**. Unplug electric chainsaw from power source. Make sure chainsaw switch is in the off position. Shut off gas powered chainsaw before attempting to sharpen the blade.
- 3) Move the dimension plate to at least a three-inch depth.
- 4) Lay the **RIPSAW** on its side with the front side facing upward.
- 5) Insert diamond stone into gullet of each tooth. While applying slight pressure upward so that , move the stone in and out (Forward and backward) in short strokes under the cutting tip of the blade.

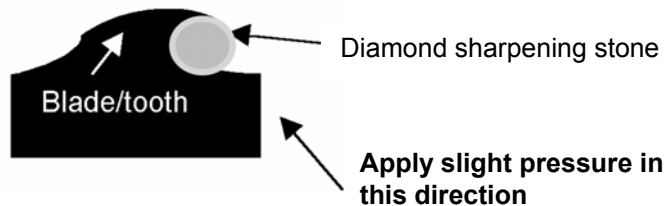

- 6) Keep the stone perpendicular or square to the blade. Two or three strokes will sharpen each tooth. (oversharpening will shorten the blade life.) Move upward on the stone as the diamond wears away to maximize stone life.

You should see that the tip of the tooth is shiny when it is dull and you should see a sharp line after it is sharpened.

Blade sharpening instructions are also located on the front of your **RIPSAW**

## ***Log Capacity***

Larger than 20" diameter logs can be cut by using the following procedure.

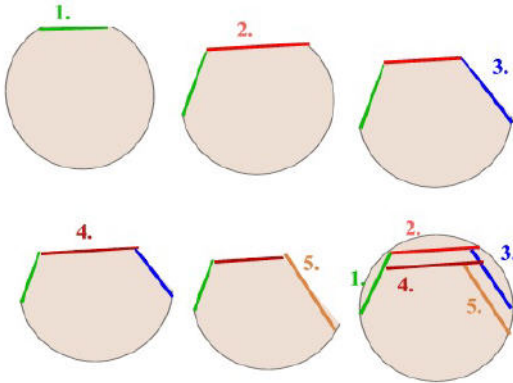

1. Make one flat trim cut as deep as possible.
2. Make a second trim cut at approximately a 30° angle to the first cut.
3. Make a third cut at a 30° angle to the second cut.
4. Cut a board off the flat from the second cut.
5. Alternate cutting surfaces until the log is small enough to be cut straight through.

The resulting boards will have to be trimmed to obtain square edges. The board thickness will be limited until the log is trimmed to at least the rated maximum capacity.

## ***Special cuts***

### ***Clapboards***

Starting with an oversized plank, clapboards can be cut by setting the dimension plate at an angle.

### ***Curved boards***

A curved board can be cut by placing a 2"x 6" board over a curved log. Cutting with the 2"x 6" as a guide will yield a curved top which can be duplicated.

## Sawing wood

1. Plan the use of your log to allow for maximum use.
2. Place the log securely on a stand or position it securely on the ground with the side you want to cut, facing upward. Having the log in an incline position will make it easier to push the mill through the log.
3. Trim off any high spots on the log using another chainsaw or the trim hatchet.
4. Position the guide beam on top of the log and secure it with the end clamps ( Keep all knobs on the same side of the log to avoid interference during the cutting process.. Adjust the height of the end clamps to accommodate any protrusions on the log. (Clamp extenders may be required. See *Figure 3*.)
5. Turn the end clamp pins so that the edges are radial to the center of the log.
6. Drive the end clamp pins into the end of the log using the hammer end of the hatchet.
7. Tighten extender and end clamp knobs.
8. Install support pin and support pin knob.
9. In setting the depth of first cut, make sure that the blade will clear the end clamps and extenders.
10. Open blade guard.
11. Gasoline powered sawmills should be started and warmed up on the ground. Electric units should be plugged into the proper size extension cord and electrical supply.
12. Place sawmill on top of guide beam and adjust guide finger to enable it to ride along the side of the guide beam.

### **Never move the RIPS AW backwards while the blade is in motion**

13. Position the **RIPSAW** at a 45° angle to the end of the log to start the cut.
14. Start cut in to log slowly.
15. Rotate sawmill to 90° after guide finger comes in contact with guide beam or log.
16. Feed the sawmill into the wood, (**Do not force**) Allow the saw to maintain a good blade speed.(This will give the best cut and will prevent overloading.)
17. Cut through the end of the log.
18. Close the blade guard and remove sawmill from the guide beam.
19. Remove the support pin from guide beam.
20. Loosen end clamp knobs and remove guide beam.
21. Wiggle end clamps to free the end clamp pins from the end of the log.
22. Remove the waste slab.
23. Rotate the log 90° (see *figure 4-framing square*)
24. Repeat the previous procedures.

This will give you your second trim cut. To yield boards with finished edges you will need to trim cut another side by dropping the dimension plate down to the maximum depth you can obtain and either guide the saw off the surface of the side you just cut or place a guide beam on top of it first. Once you have three trim sides you are now ready to cut boards with finished edges.

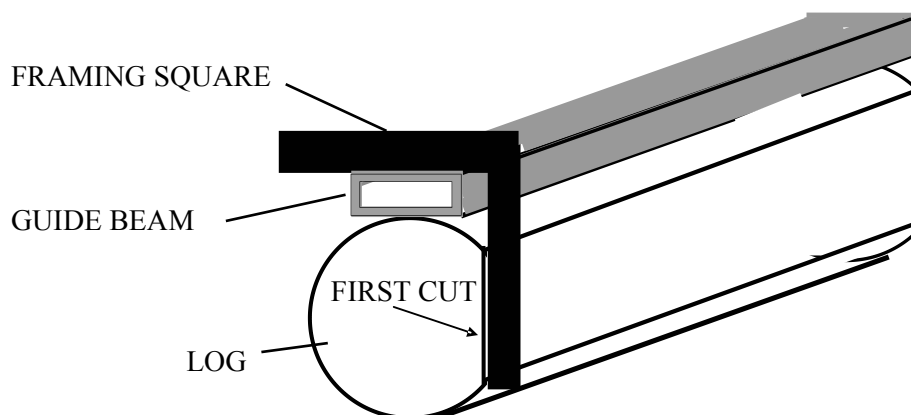

## ***Warranty***

### ***6 Month warranty on RIPS AW parts***

Every **RIPS AW** is thoroughly inspected and tested before leaving the factory. Should a ny trouble develop with the saw or its components, please contact our office AT 256-728-3070 for further instructions. Returns will not be accepted without prior authorization. Upon the completion of any warranty work, the items repaired will be shipped back to you, freight pre-paid.

The RIPS AW warranty does not apply under these conditions:

1. Repairs are necessary due to normal wear.
2. Repairs have been attempted or made by someone other than S.I.R. personnel.
3. The unit has been in an accident.
4. Misuse is evident. (Such as: overloading or operating beyond rated capacity)
5. The unit has been operated after partial failure.
6. The unit has been used with an improper accessory.

## ***Guarantee***

Southeastern industrial Resources stands behind each of its **RIPS AW** portable sawmills with a 30-day, money-back guarantee. Authorization must be obtained prior to the return of any S.I.R. product. Refunds will be less shipping and a 20 % restocking charge.