

Ripsaw Carriage System

assembly instructions

www.rip-saw.net

Southeastern Industrial Resources
PO Box 266, Grant, AL 35747
256-728-3070, fax 256-728-3071

RAIL ASSEMBLY INSTRUCTIONS

- WHAT YOU WILL NEED:**
- 1 pc. 28-1/16" L for RAIL SPACER (Not shown)
 - 12 pcs. 25-1/2"-2X4'S CROSS BRACES
 - 6 pcs. 32-1/4" - 2X4'S CROSS BRACE
 - 10 pcs. 32" - 2X4'S SIDE RAIL SPACER (LAYER 2)
 - 4 pcs. 16' -2X4'S OR 2X4'S CUT LONG ENOUGH NOT TO OVERLAP CROSS OVER SPACERS (SIDE RAIL SUPPORTS – LAYERS 1 AND 3) SEE DIAGRAM BELOW

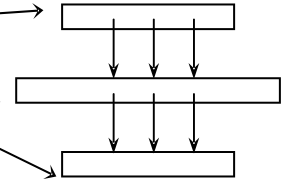

1. CROSS BRACE ASSEMBLY
ASSEMBLE FIVE CROSS BRACE SECTIONS AS SHOWN.

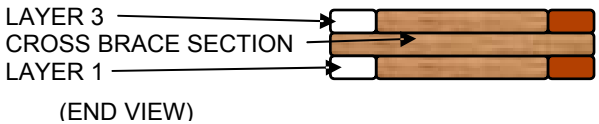

2. LAYER 1

PLACE (2) 2"X4"X16' BOARDS ON A FLAT AREA (16' is based on the standard carriage setup. You will need longer boards if you have additional rails.)

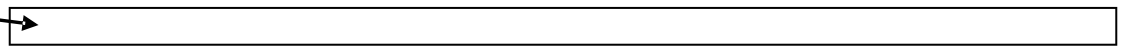

3. LAYER 2

- A PLACE A CROSS BRACE SECTION ON THE END OF THE RAIL SUPPORTS, SQUARE IT UP AND NAIL OR SCREW SECURELY.
- B INSTALL A 2X4X32" BOARD ON EACH SIDE AND NAIL SECURELY.
- C REPEAT STEPS A AND B TO COMPLETE THE SECOND LAYER OF THE RAIL SUPPORT FRAME.

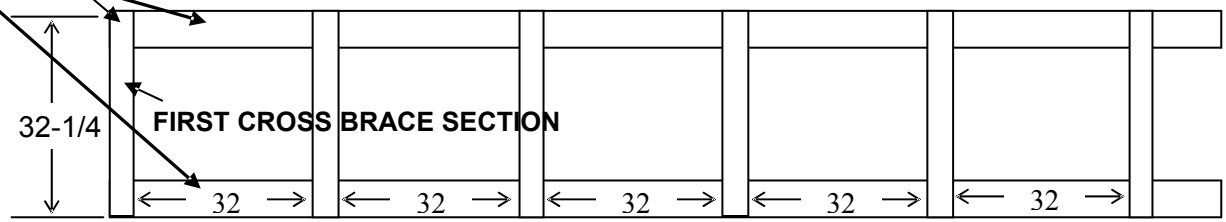
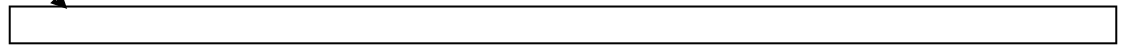

LAYER 3

- A PLACE (2) 2X4X16' BOARDS ON TOP OF LAYER 2 (1 BOARD PER SIDE) AND NAIL OR SCREW SECURELY.

SIDE VIEW USING 2 – 2"X4"X16' BOARDS FOR LAYER 1 AND 3

INSERT A 2X4 TO STABILIZE FRAME, BUT DO NOT FASTEN IT IN CASE YOU WANT TO ADD RAILS IN THE FUTURE

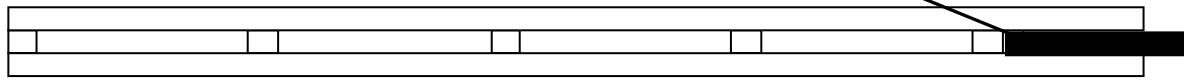

SIDE VIEW USING ALTERNATIVE LENGTH 2X4'S FOR LAYER 1 AND 3

SEAMS MUST NOT OVERLAP TO INSURE STRENGTH

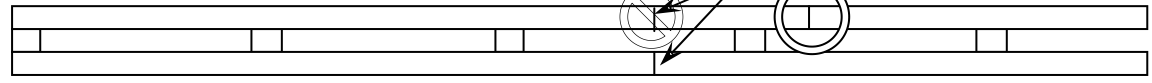

RAIL ASSEMBLY AND INSTALLATION

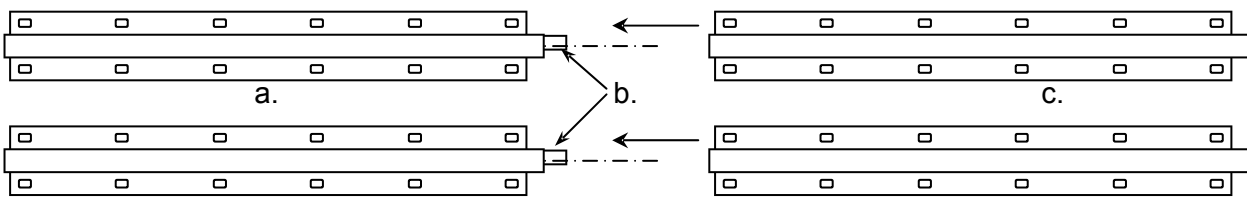

Do NOT lift the rails while they are assembled. Doing so will distort the rail.

1. PLACE RAILS ON TOP OF RAIL SUPPORT FRAME.
2. INSERT NURLED END OF 2 RAIL CONNECTING PINS (b.) INTO 2 RAILS (a.) (AS SHOWN).
3. SECURE PINS BY TAPPING THEM IN, USING A BLOCK OF WOOD AND A HAMMER.
4. INSTALL SECONDARY RAILS (c.) ONTO CONNECTING PINS.
5. USING A PIECE OF STRING, AS A GUIDE, ALIGN 1 RAIL SET.
6. SCREW THE RAIL TO THE RAIL SUPPORT FRAME, BEING SURE TO KEEP THE CONNECTED RAILS ALIGNED.
7. PLACE THE 2nd RAIL SET ON TOP OF THE OPPOSITE SIDE OF THE RAIL SUPPORT FRAME.
8. PLACE THE RAIL SPACER ACROSS THE RAIL SUPPORT FRAME SO THAT IT TOUCHES THE RAIL THAT IS ALREADY FASTENED TO THE FRAME. THE SPACER SHOULD BE TOUCHING THE "PIPE" PART OF THE RAIL. (SEE DIAGRAM BELOW)
9. DRIVE A SCREW INTO THE FIRST TWO SLOTS IN RAIL.
10. MOVING SPACER ALONG THE RAIL, INSTALL SCREWS CONSECUTIVELY..
11. REPEAT STEPS 7-10 WHERE APPLICABLE.

THE REMAINING

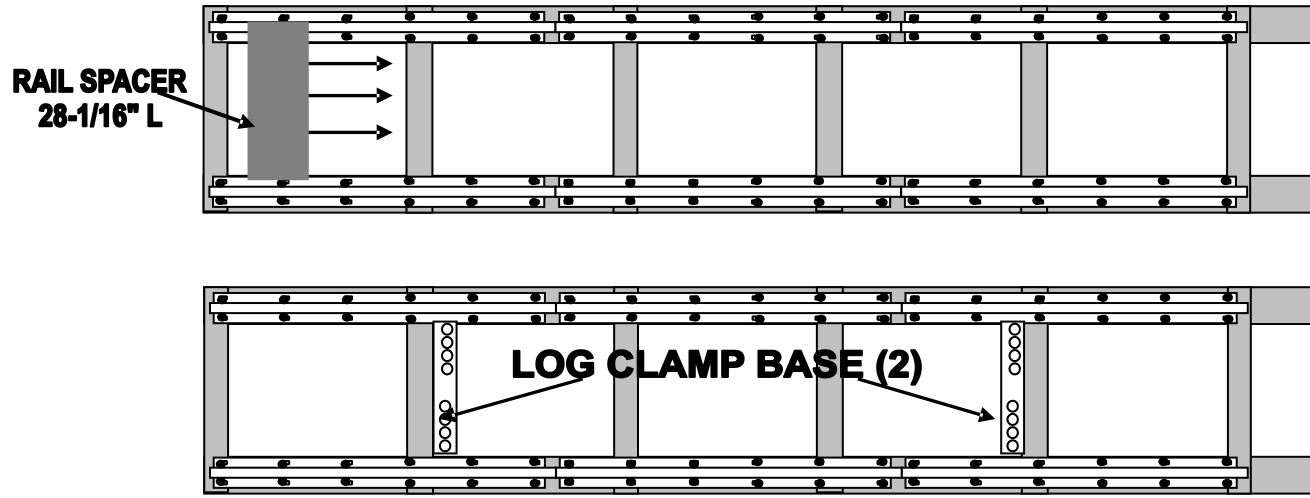
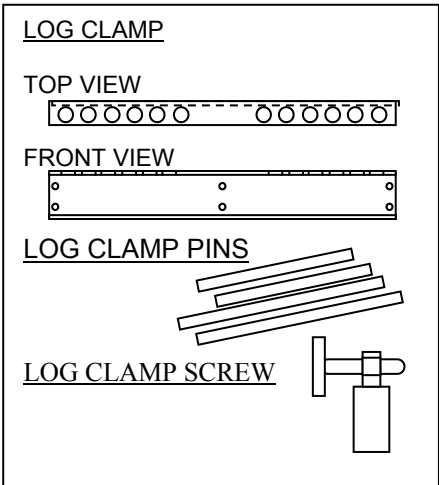

LOG CLAMP INSTALLATION

1. PLACE ONE LOG CLAMP AGAINST 2nd CROSS BRACE AND FASTEN WITH LOG CLAMP SCREWS (6).
2. PLACE THE OTHER LOG CLAMP AGAINST THE NEXT TO LAST CROSS BRACE AND FASTEN WITH LOG CLAMP SCREWS (6).

CARRIAGE BASE ASSEMBLY

- A RIGHT CARRIAGE BASE
- B LEFT CARRIAGE BASE
- C ACME THREADED ROD (2)
- D STABILIZER SHAFT
- E 3/8-16 BOLTS (2)
- F CARRIAGE SAFETY RETAINER & SAFETY RETAINER NUT.

ASSEMBLE CARRIAGE BASE AS SHOWN IN DIAGRAM

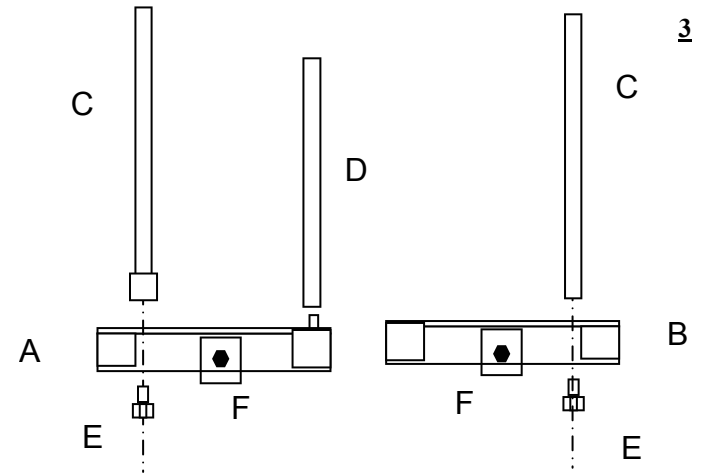

CARRIAGE CRANK HANDLE ASSEMBLY

TIGHTEN BOTTOM NUT AGAINST LEVER
BE SURE THAT HANDLE SPINS FREELY

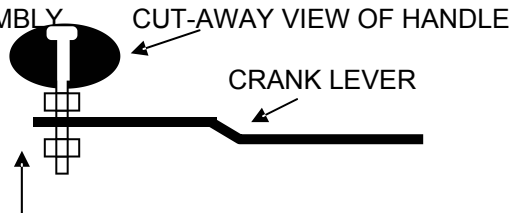

MOUNTING CARRIAGE BASE and CARRIAGE

1. SLIDE CARRIAGE BASE PIECES ONTO RAILS.
2. TIGHTEN CARRIAGE SAFETY RETAINER NUTS
3. UNTIL IT CONTACTS RAIL ON BOTH SIDES.
4. BACK OFF NUT ONE FULL TURN, MAKE SURE THE BASE ROLLS EASILY ON THE RAILS.
5. PLACE CARRIAGE ONTO ACME THREADED RODS.
6. ALIGN STABILIZER SHAFT.
7. CRANK CARRIAGE HANDLE ENOUGH TO ENGAGE STABILIZER SHAFT.

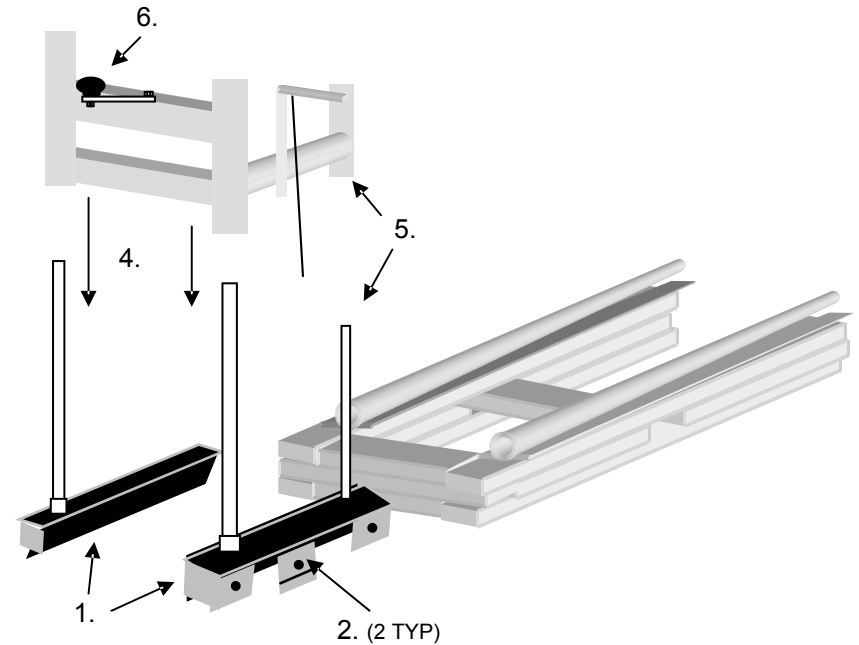

THROTTLE CONTROL MOUNTING

1. REMOVE 1/4-20 BOLT AND 10-32 SCREW AS SHOWN.
2. MOUNT THROTTLE MOUNTING BRACKET. (CHAINSAW DOES NOT HAVE TO BE REMOVED FOR THIS PROCEDURE.)

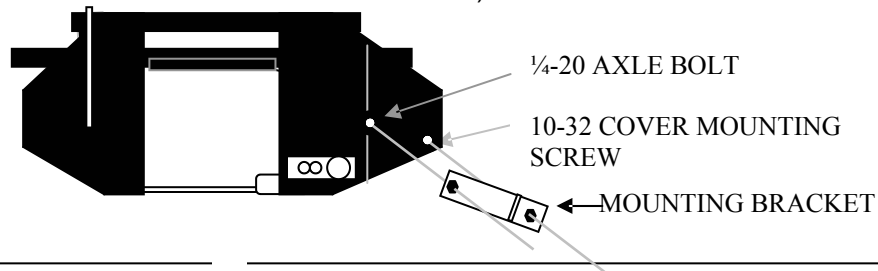

ATTACHING SAWMILL TO CARRIAGE

1. LOOSEN BLADE TENSION.
2. REMOVE FRONT COVERS FROM SAWMILL.
3. INSTALL 3/8" THREADED RODS (2) INTO SLOTS WITH RODS POINTING OUTWARD.
4. REMOVE 1/4-20 BOLT.
5. REPLACE 1/4-20 BOLT WITH 1/4-20 THREADED ROD.
6. REPLACE FRONT COVERS AND RETENSION BLADE.

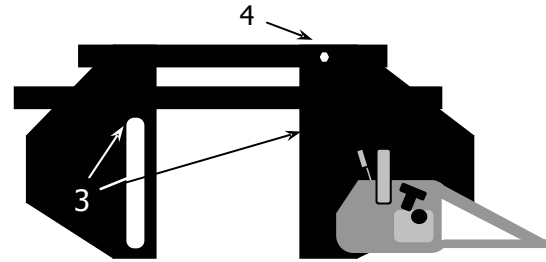

4

7. SLIDE MOUNT SPACERS ONTO THREADED RODS (3).
8. LIFT SAWMILL AND ALIGN THREADED RODS WITH HOLES ON CARRIAGE.
9. SLIDE THREADED RODS THROUGH CARRIAGE
10. SECURE WITH APPRPRPIATE NUTS.

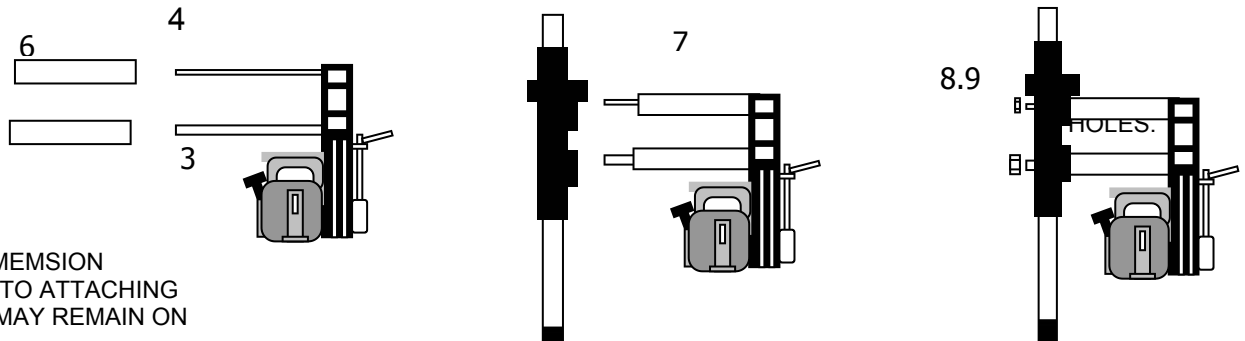

* TO ALLOW FOR MAXIMUM CUTTING DEPTH THE DIMENSION PLATE SHOULD BE REMOVED FROM SAWMILL PRIOR TO ATTACHING IT TO CARRIAGE, HOWEVER, THE DIMENSION PLATE MAY REMAIN ON THE SAWMILL WHILE USING THE CARRIAGE SYSTEM.

THROTTLE CONTROL MOUNTING (continued)

1. ROTATE THROTTLE CONTROL HANDLE TO THE UPRIGHT POSITION AS SHOWN .
2. TIGHTEN U BOLT NUTS (E)
3. INSERT THROTTLE WIRE (C) INTO HOLE ON THROTTLE JOINT BRACKET (A).
4. MOUNT THROTTLE JOINT BRACKET (A) TO THROTTLE CONTROL MOUNT (B).
5. SLIDE WIRE RETAINER (D) ONTO THROTTLE WIRE (C).
6. ADJUST WIRE RETAINER SO THAT BOTH TRIGGERS ARE IN THE "DOWN" OR "OFF" POSITION
7. TIGHTEN WIRE RETAINER BY TURNING THE SETSCREW.
8. PLACE THROTTLE CLIP (F) OVER CHAINSAW HANDLE IN ORDER TO ACTIVATE THROTTLE CONTROL.*

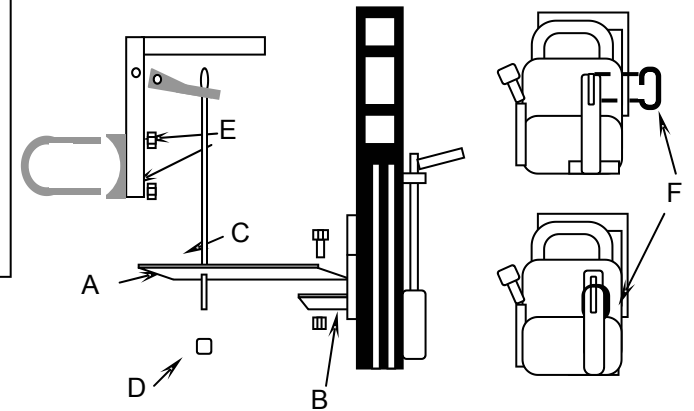

! WARNING !

THROTTLE CLIP MUST BE REMOVED WHILE SAWMILL IS NOT ATTACHED TO CARRIAGE

FAILURE TO HEED THIS WARNING MAY RESULT IN PERSONAL INJURY

INSTALLING CARRIAGE LOCK HANDLES

AFTER CARRIAGE IS ASSEMBLED TO THE CARRIAGE BASE;

1. INSERT CARRIAGE LOCK BUTTONS INTO HOLES
2. INSTALL CARRIAGE LOCK SCREWS
FAILURE TO INSTALL BUTTONS PRIOR TO INSTALLING LOCKING SCREWS WILL DAMAGE ACME THREADED ROD AND WILL RESULT IN CARRIAGE OPERATION FAILURE.

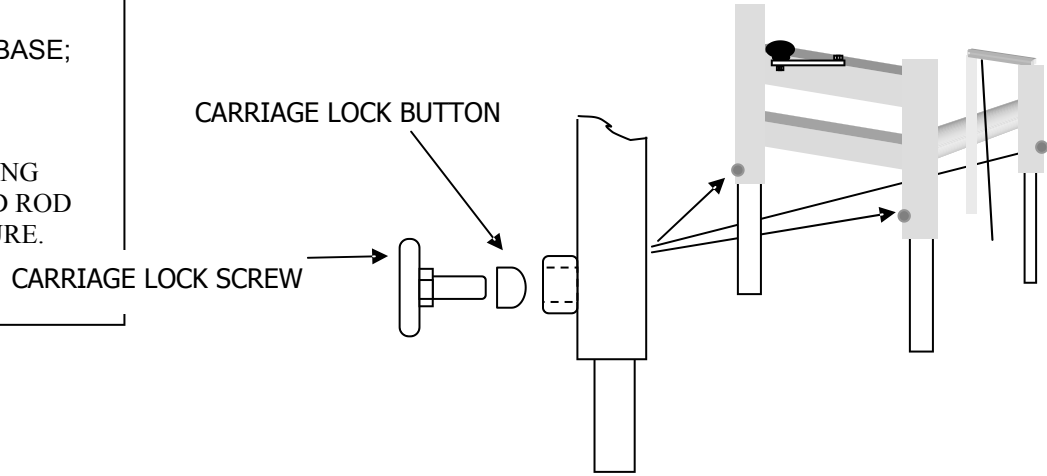

LOG CLAMP SCREWS

USE WITH SHORT LOG CLAMP PINS TO STABILIZE LOG AS SHOWN)

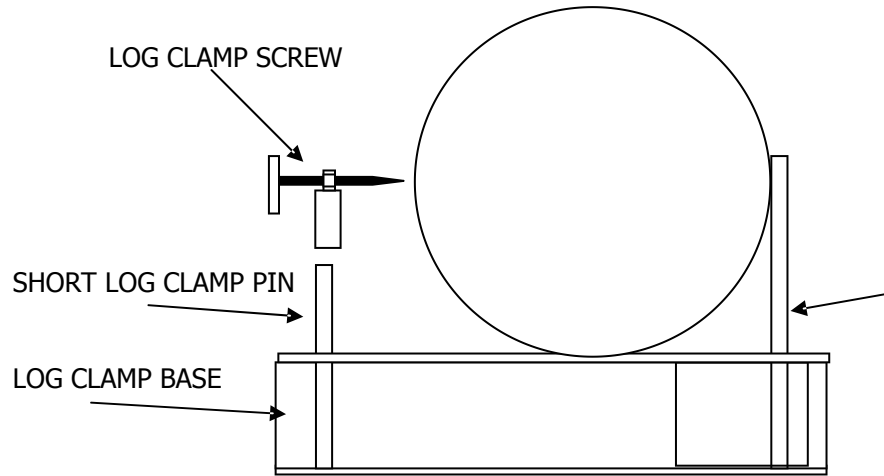

RIPSAW CARRIAGE OPERATING INSTRUCTIONS

1. POSITION LOG ON LOG CARRIAGE SYSTEM.
2. RAISE THE SMALLER END OF THE LOG TO MAKE THE CENTERLINE PARALELL TO THE RAILS.
3. INSERT LONG LOG CLAMP PINS (ONE AT EACH END OF LOG) SO THAT THEY ARE AGAINST THE LOG.
4. INSERT SHORT LOG CLAMP PINS AND LOG CLAMP SCREWS ON OPPOSITE SIDE OF LOG.
5. BE SURE ALL PINS ARE LOW ENOUGH SO THEY WILL NOT INTERFERE WITH BLADE WHILE CUTTING.
6. TIGHTEN LOG CLAMP SCREWS.
7. LOOSEN (3) CARRIAGE LOCKING SCREWS.
8. SET THE CUTTING DEPTH BY TURNING HEIGHT ADJUSTMENT HANDLE.
9. START ENGINE.
10. TIGHTEN (3) CARRIAGE LOCKONG SCREWS.
11. OPEN BLADE GUARD.
12. FEED SAW THROUGH LOG BY PUSHING ON TOP PART OF CARRIAGE AND THROTTLE CONTROL.
13. AFTER COMPLETING CUT, REMOVE SLAB AND RETURN CARRIAGE TO THE START POSITION.
14. TURN LOG 90 DEGREES WITH CUT SIDE SQUARE AGAINST LONG LOG CLAMP PINS.
15. ELEVATE SMALL END OF LOG AS IN STEP 2.
16. POSITION SHORT LOG CLAMP PINS AND LOG CLAMP SCREWS AND TIGHTEN.
17. SET DEPTH OF CUT.
18. PROCEED TO MAKE SECOND CUT FOLLOWING STEPS 3 THROUGH 13.
19. AFTER COMPLETING CUT, REMOVE SLAB AND RETURN CARRIAGE TO THE START POSITION
20. IF THE LOG IS STILL LARGER THAN 14" WIDE OR IF YOU WANT FINISHED EDGES YOU MUST ROTATE THE LOG AS BEFORE AND MAKE ANOTHER SLAB CUT.
21. AFTER COMPLETING THIRD CUT, REMOVE SLAB AND RETURN CARRIAGE TO THE START POSITION
22. CLAMP AND CUT FOURTH SLAB
23. AFTER COMPLETING FOURTH CUT, REMOVE SLAB AND RETURN CARRIAGE TO THE START POSITION
24. SET THE DEPTH OF CUT FOR FINISHED LUMBER BY TURNING THE HEIGHT ADJUSTMENT HANDLE
(1 TURN EQUALS ¼ INCH OR 4 TURNS EQUALS 1 INCH.)
25. ADD ¼ TURN TO ALLOW FOR BLADE THICKNESS.
26. CHECK DEPTH WITH RULER AND MAKE ANY NECESSARY ADJUSTMENTS.
27. CHECK HEIGHT OF LOG CLAMP PINS AND MAKE ANY NECESSARY ADJUSTENTS
28. PROCEED TO CUT FINISHED LUMBER.
29. REPEAT STEPS 22 THROUGH 27 AS NEEDED.